



4727 E. Hedges
Fresno, CA 93703
(559) 255-0527
FAX (559) 253-1952
www.snowwhiteltd.com

Shortie Water Pump Kit Instructions

Our 289/302/351W and 351C Shortie Water Pump Kit is available for 1963 to 1988** Windsor and Cleveland Engines. Kits are based on a standard 1900 cc German Opal Water Pump. (Opal Kadett, Opal Manta GT 1.9L)

** will fit 1988 and later 5.0L engines with OEM serpentine reverse rotation WP with slight modifications to front cover. (See below)

Kits include: Adapter Plate, Machined Aluminum Crank and Pump, Pulleys, New Aluminum Pump, Gaskets, Hardware and Instructions.

Backplate from original water pump on your engine must be retained and used on our Shortie Water Pump Adapter Plate as part of Kit.

Please Note:

Customers with 1966 to 1971 221/265/289/302/351 Ford Windsor engines with cast iron water pump or 1982 and later 302W with Aluminum water pump, must obtain their own 1972 thru 1981 water pump backplate; Backplate is 1972 to 1981 type = dead flat .100" thick, no pancake upset in center of plate.

Owners of 1963 to 1965 221/260/289 Ford engines may use this conversion, however, the timing cover and crank dampener (harmonic balancer) must be changed to a 1967 to 1971 Ford 289/302 timing cover and crank dampener.

The early 1963 thru 1965 Ford engine is identified by an aluminum water pump with no steel plate between water pump and timing cover, uses Victor gasket #K27579 engine has 5 bolt bell housing. (1965-1/2 and later engines have 6 bolt housing)

Lower hose (inlet) on our Shortie Pump is on the passenger side which is the same as SB Chevy lower hose (1 3/4" diameter) Radiator can be ordered as if engine were a SB Chevy (can't get away from 'em) Contrary to most Ford Owners popular belief our records show that there is approximately a 50% distribution between what is considered the Ford inlet (Drivers side) and the passenger's side (SB Chevy side) inlet.

Water pump pulley is single groove; Crank pulley has a Double groove.
For AC set-up: WP pulley Dbl groove; Crank pulley Triple groove (4Bolt only).
We do not offer a 3Bolt Triple groove early crank pulley.

The Shortie Water Pump Kit is Two Inches Shorter than the Stock Ford Pump. We can furnish a combination AC?Alt bracket Kit (Zoops Aluminium).

Alternator Only Bracket (steel) for the 289/302/351 Windsor engines.

Alternator only Bracket (steel) for the 351C (Cleveland) engines.

Shortie Adapter, Pump, and both Pulleys weight:	7-3/4 lbs
Stock Ford CI Pump and both Pulleys weight:	21-1/2 lbs
Net Weight Difference:	13-3/4 lbs

READ THIS! READ THIS! READ THIS! READ THIS! READ THIS! **INSTALLATION NOTES**

V-Belt on water pump pulley comes VERY close to lower radiator hose and hose clamp;

- Install hose as low as possible on water pump inlet
- Leave very little (maybe 1/8") of the hose extending above the clamp
 - a) hose may be shortened for proper length
- Position hose clamp screw so as to clear V-belt.
 - After clamp is tightened properly, some of the hose that extends above the clamp will squeeze or tulip out.
 - Belt will touch and groove a notch in this portion of the belt when the engine is first started or cranked. Hey!!, Come on, this is HOT ROD isn't it?

We do not make a double groove water pump pulley; note that the single belt groove that is at the REAR of the WP pulley, lines up with the FRONT groove in the crank pulley; this would be the normal configuration with alternator only.

SVO ENGINES:

- For those fortunate few that have LATE SVO engines with Stock Ford serpentine drive:
- The water pumps on these engines rotate counterclockwise; therefore the front timing cover, gaskets, and stock pump water passages are configured for anti-clockwise water flow.
- The Shortie pump, which is normal clockwise rotation, will fit right on to the SVO timing cover; however some of the extra holes in the front cover under the gasket surface must be plugged with **5/16-18 allen setscrews; use ultra-blue silicone sealer on gasket and set screw threads.**

Alternately, cover may be changed to the early (67-82) front cover which has the normal clockwise rotation.

BEFORE YOU GET INTO HOT WATER WE STRONGLY RECOMMEND:

- 1 **USE A RECOVERY TANK AND PRESSURE CAP:**
 - a. Pressure cap should be as high as radiator tank will stand.
- 2 **USE RUST INHIBITOR: EITHER OR BOTH:**
 - a. Antifreeze 25% solution.

b. Soluble oil and water solution.

3 DRILL BYPASS HOLES IN THERMOSTAT:

We Do Not Use a Bypass Hole on The Riser Pump; Bypass is Used In Passenger Car Heater Warm Up, and to Circulate Water In the Block When the Thermostat Is Closed; You Must Provide a Means For Water to Circulate In The Engine With a Closed Thermostat:

(See Instruction Sheet Also)

a. Drill three 1/16" holes in thermostat plate.

b. OR: knock out center valve and use the plate only

c. If You Have No Car Heater: Run a Hose From One of the Front 1/2" Holes On Intake Manifold To the Heater Hose Nipple On the Water Pump Inlet, However, you must:

d. Restrict the flow of water to the pump by soldering a plug in the hose fitting or inserting a plug in the hose with a 3/16 or 1/4 inch hole.

4 USE ENGINE DRIVEN FAN → IF AT ALL POSSIBLE:

a. Electric fan is a poor second choice in most cases.

*FIGURE NOT DRAWN TO SCALE

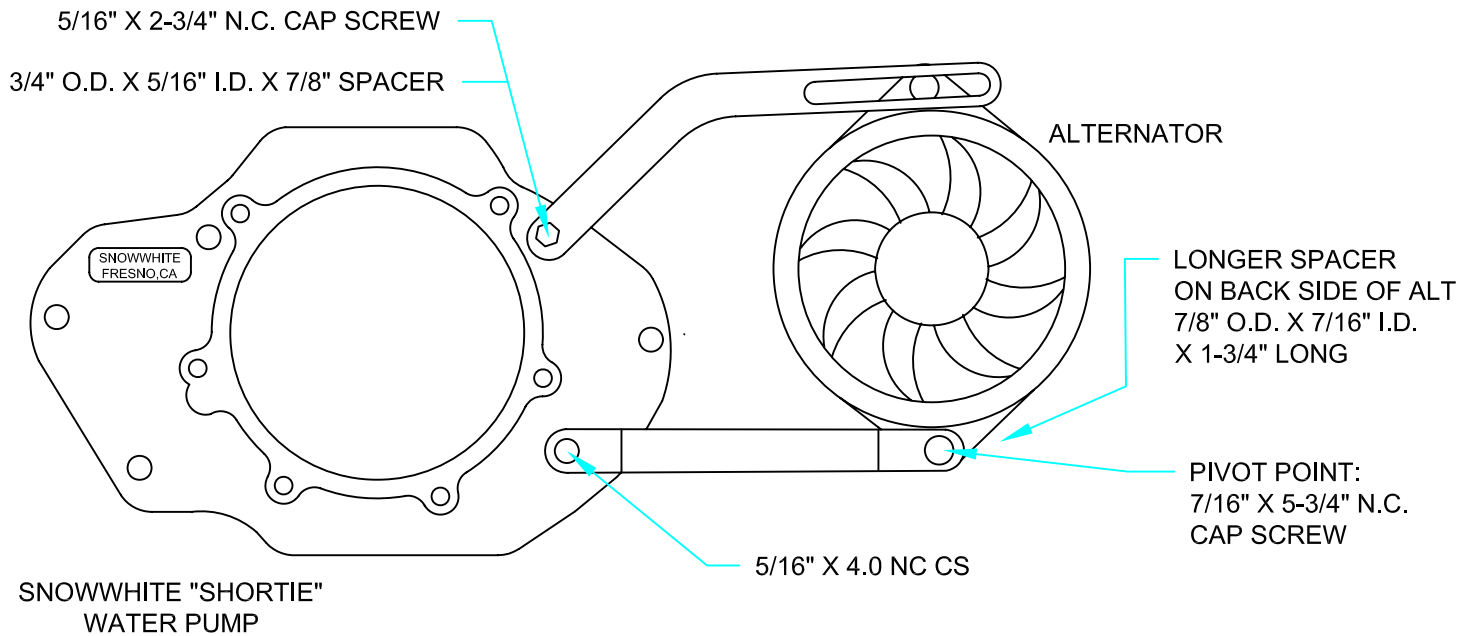

ALTERNATOR MAY BE PIVOTED OFF ANY BOLT HOLE. 1-3/4" SPACER FITS BETWEEN ALTERNATOR AND HEAD. (7/8" O.D. X 7/16" I.D. X 1-3/4")

V-BELT 38-1/2" DAYCO 15385